

Through-penetration Firestop Systems

System No. C-AJ-1761

ANSI/UL1479 (ASTM E814)	CAN / ULC S115
F Rating — 3 Hr	F Rating – 3 Hr
T Rating — 1/4 or 1/2 Hr (see Item 2)	FT Rating – 1/4 or 1/2 Hr (see Item 2)
	FH Rating – 3 Hr
	FTH Rating – 1/4 or 1/2 Hr (see Item 2)

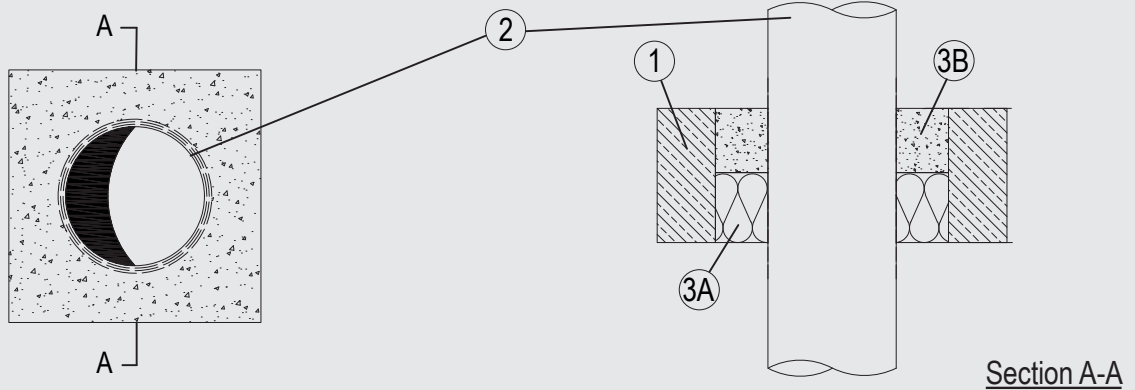

System tested with a pressure differential of 2.5 Pa between the exposed and the unexposed surfaces with the higher pressure on the exposed side.

1. Floor Assembly

Min. 4-1/2 in. (115 mm) thick normal weight (nom. 135-150 pcf or nom. 2160-2400 kg/m³) concrete. Wall may also be constructed of any UL Classified Concrete Blocks*. Opening shall be circular or rectangular with max diameter or dimensions of 7 in. (180 mm). See Concrete Blocks (CAZT) category in UL ProductIQ for names of manufacturers.

2. Through Penetrant

One pipe or tubing to be installed concentrically within the firestop system. The annular space between the pipe and the periphery of the opening to be 0.4 in (10 mm). Pipe or tubing to be rigidly supported on both sides of floor or wall assembly. The following types and sizes of pipes or tubes may be used:

- A. Copper pipe - Nom 6-1/4 in. (159 mm) diameter (or smaller) 0.12 in (3 mm) (or thicker) copper pipe.
- B. Copper pipe - Nom 1-3/8 in. (35 mm) diameter (or smaller) 0.059 in (1.5 mm) (or thicker) copper pipe.

The hourly T, FT and FTH Ratings shall not exceed 1/4 hr when Item 2A is used.

3. Through-Penetration Firestop System

The Through-Penetration Firestop System shall consist of the following:

- A. Packing material — Min 2-3/8 in. (60 mm) thickness of min 6 pcf (100 kg/m³) mineral wool insulation firmly packed into annulus as a permanent form. Packing material to be installed flush to bottom surface of floor or one surface of wall.
- B. Fill, Void or Cavity Material* — Min 2-1/8 in. (55 mm) cast into annular space between pipe and periphery of opening, flush with top surface of floor or one surface of wall. Mortar to be mixed with water in accordance with the manufacturer's installation instructions.

SVT BRANDSCHUTZ VERTRIEBSGESELLSCHAFT MBH INTERNATIONAL — PYRO-SAFE GFM

*Indicates such products shall bear the UL or cUL Certification Mark for jurisdictions employing the UL or cUL Certification (such as Canada), respectively.

Please contact us for further information:

Information: global@svt.de Order: order@svt.de
 +49 4105-40 90-0