

Through-penetration Firestop Systems

System No. W-L-3443

ANSI/UL1479 (ASTM E814)	CAN / ULC S115
F Rating — 2 Hr	F Rating – 2 Hr
T Rating — 1 Hr	FT Rating – 1 Hr
	FH Rating – 2 Hr
	FTH Rating – 1 Hr

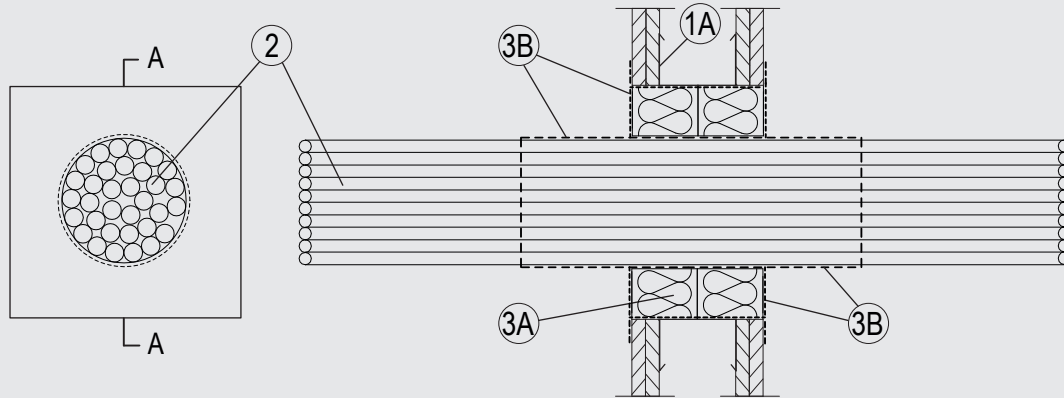

Section A-A

1. Wall Assembly

The 1 or 2 hr fire rated gypsum board/stud wall assembly shall be constructed of the materials and in the manner described in the individual U400, V400 or W400 Series Wall and Partition Design in the UL Fire Resistance Directory and shall include the following construction features:

- A. Studs (not shown in diagram) — Steel studs to be min 2-3/4 in. (70 mm) wide spaced max 24 in. (610 mm) OC. Additional studs used to completely frame the opening.
- B. Gypsum Board* — The gypsum board type, thickness, number of layers, fastener type and sheet orientation shall be as specified in the individual Wall and Partition Design in the UL Fire Resistance Directory. Max size of opening to be 8 in. (200 mm) high by 8 in. (200 mm) wide.

2. Cables

Bundle of 4" (100 mm) diameter of the following types and sizes of cables may be used:

- A. Max 20/C No. 19 AWG (0.6 mm) diam (or smaller), copper conductor telecommunication cables PE jacket.

3. Firestop System

The Firestop System shall consist of the following:

- A. Packing Material — Nom. 2-3/8 in. (60 mm) thick mineral wool boards min. 9.3 pcf (150 kg/m³) firmly packed into the opening of the wall as a permanent form. Packing material to be installed flush with both surfaces of wall.
- B. Fill, Void or Cavity Material* — Min. 1/16 in. (2 mm) dry film thickness to be applied, coating the inside surface of the opening before installation of the packing material and over the full surface of the mineral wool boards, and overlapping onto the wall by min. 3/4 in. (20 mm). Min. 1/32 in. (1 mm) dry film thickness to be applied over the surface of the cables to a minimum length of 8 in. (200 mm) from both faces of the board.

SVT BRANDSCHUTZ VERTRIEBSGESELLSCHAFT MBH INTERNATIONAL — PYRO-SAFE FLAMMOTECT A

*Indicates such products shall bear the UL or cUL Certification Mark for jurisdictions employing the UL or cUL Certification (such as Canada), respectively.

Please contact us for further information:

✉ Information: global@svt.de Order: order@svt.de
 ☎ +49 4105-40 90-0