

Through-penetration Firestop Systems

System No. W-J-8062

ANSI/UL1479 (ASTM E814)	CAN / ULC S115
F Rating — 2 Hr	F Rating – 2 Hr
T Rating — 1 - 1/2 Hr	FT Rating – 1 - 1/2 Hr
	FH Rating – 2 Hr
	FTH Rating – 1 - 1/2 Hr

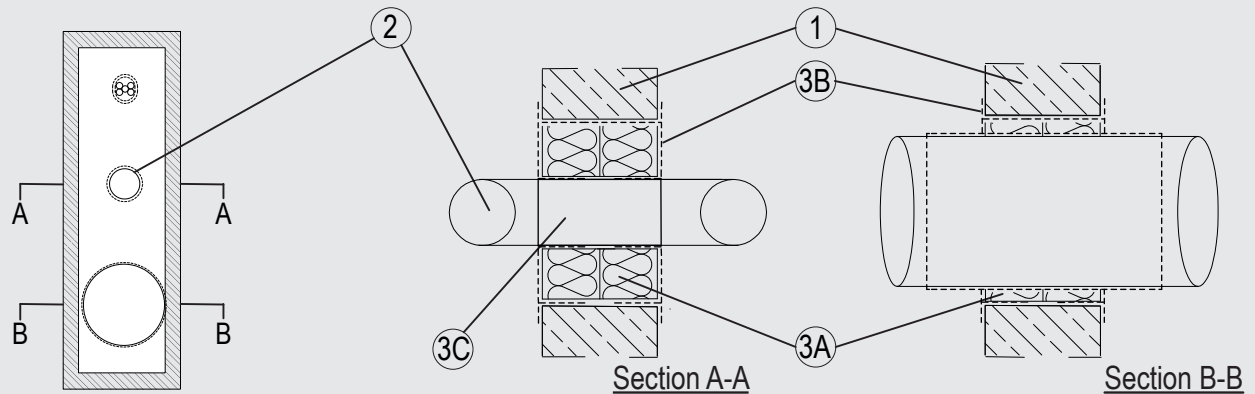

System tested with a pressure differential of 2.5 Pa between the exposed and the unexposed surfaces with the higher pressure on the exposed side.

1. Wall Assembly

Min 4-1/2 in. (115 mm) thick lightweight or normal weight (100-150 pcf or 1600-2400 kg/m³) concrete. Wall may also be constructed of any UL Classified Concrete Blocks*. Opening shall be rectangular with max dimensions of 23-5/8 in. (500 mm) by 6-1/4 in. (160 mm).

* See Concrete Blocks (CAZT) in the Fire Resistance Directory for names of manufacturers.

2. Services

Services to be incorporated shall consist of the following:

- A. Max 1/C 148 mm diameter (or smaller), copper conductor cable with XLPE insulation and HDPE jacket. The annular space between the cable and the periphery of the opening to be 0-2 in (0-50 mm).
- B. Nominal 1-1/2 in (37mm) diameter PE-HD SRV-G 7x10 tc 'speed pipe' for use in closed (process or supply) piping systems. The annular space between the pipe and the periphery of the opening to be 2 in (50 mm).
- C. Nominal 2-1/4 in. (56 mm) diameter HD 240 synthetic rubber hydraulic hose for use in closed (process or supply) piping systems. The annular space between the pipe and the periphery of the opening to be 2 in (50 mm).

3. Firestop System

The Firestop System shall consist of the following:

- A. Packing material — 2 layers of Nom. 2-3/8 in. (60 mm) thick mineral wool board min. 9.3 pcf (150 kg/m³) firmly packed into the opening of the wall as a permanent form.
- B. Fill, Void or Cavity Material* — Min. 1/16 in. (2 mm) dry film thickness to be applied inside the aperture before installation and over the full surface of the mineral wool boards, and overlapping onto the wall by min. 3/4 in. (20 mm). Min. 1/32 in. (1 mm) dry film thickness to be applied over the surface of the cables and tray to a minimum length of 10 in. (254 mm) from both faces of the board.
SVT BRANDSCHUTZ VERTRIEBSGESELLSCHAFT MBH INTERNATIONAL — PYRO-SAFE FLAMMOTECT A
- C. Fill, Void or Cavity Material* — 1 layer of 1/16 in (1.5 mm) by 5 in. (125 mm) wrap positioned centrally within the depth of the seal around hydraulic pipe. 2 layers of 1/16 in (1.5 mm) by 5 in. (125 mm) wrap positioned centrally within the depth of the seal around speed pipe.
SVT BRANDSCHUTZ VERTRIEBSGESELLSCHAFT MBH INTERNATIONAL — PYRO-SAFE DG-CR 1.5"

*Indicates such products shall bear the UL or cUL Certification Mark for jurisdictions employing the UL or cUL Certification (such as Canada), respectively.

Please contact us for further information:

Information: global@svt.de Order: order@svt.de
+49 4105-40 90-0