

Through-penetration Firestop Systems

System No. C-AJ-2938

ANSI/UL1479 (ASTM E814)

F Rating — 3 Hr
T Rating — 2 and 3 Hr (see item 2)

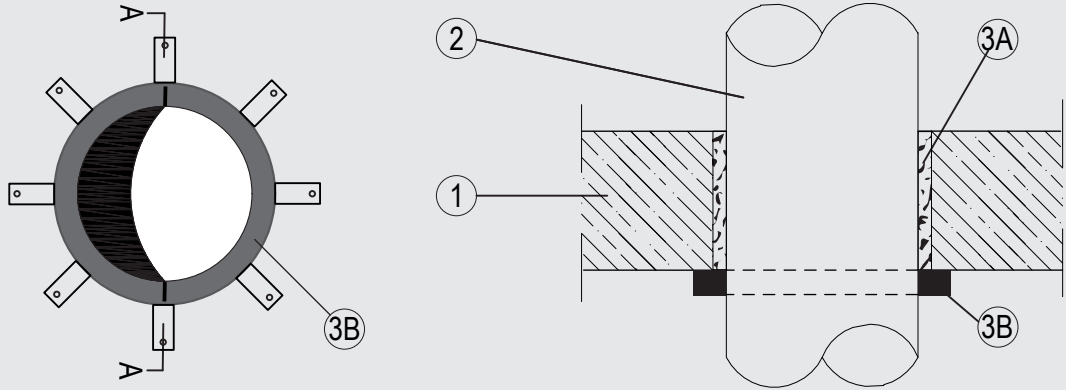

System tested with a pressure differential of 2.5 Pa between the exposed and the unexposed surfaces with the higher pressure on the exposed side.

1. Floor Assembly

Min. 4-1/2 in. (115 mm) thick normal weight (nom. 135-150 pcf or nom. 2160-2400 kg/m³) concrete. Wall may also be constructed of any UL Classified Concrete Blocks*. Opening shall be circular or rectangular with max diameter or dimensions of 9-2/3in. (245 mm). See Concrete Blocks (CAZT) category in UL ProductIQ for names of manufacturers.

2. Pipes/ Tubes

Single to be installed within the opening. The annular space between the pipes and the periphery of the opening to be 0.4 in (10 mm). Pipes to be rigidly supported on both sides of the floor assembly. The following penetrants may be used:

- A. Nom 8.9 in (225 mm) diam 0.8 in (20.5 mm) wall thickness PE pipe for use in closed (process or supply) piping systems.
- B. Nom 8.9 in (225 mm) diam 0.8 in (20.5 mm) wall thickness PP pipe for use in closed (process or supply) piping systems.

When Item 2B is used, the T Rating shall not exceed 2 hr.

3. Firestop System

The Through-Penetration Firestop System shall consist of the following:

- A. Packing Material — Min 4-1/2 in. (115 mm) thickness of min 6 pcf (100 kg/m³) mineral wool insulation firmly packed into annulus as a permanent form. Packing material to be installed flush with both surfaces of floor or wall.
- B. Firestop Device*
Galv steel collar lined with an intumescent material sized to fit the specific diam of the through-penetrant. Device shall be installed around through-penetrant in accordance with the accompanying installation instructions on the exposed side of floor or both sides of wall.

SVT BRANDSCHUTZ VERTRIEBSGESELLSCHAFT MBH INTERNATIONAL — ROKU AWM II

*Indicates such products shall bear the UL or cUL Certification Mark for jurisdictions employing the UL or cUL Certification (such as Canada), respectively.

Please contact us for further information:
 Information: global@svt.de Order: order@svt.de
 +49 4105-40 90-0