

Through-penetration Firestop Systems

System No. C-AJ-1691

ANSI/UL1479 (ASTM E814)	CAN / ULC S115
F Rating — 3 Hr	F Rating – 3 Hr
T Rating — 0 Hr	FT Rating – 0 Hr
	FH Rating – 3 Hr
	FTH Rating – 0 Hr

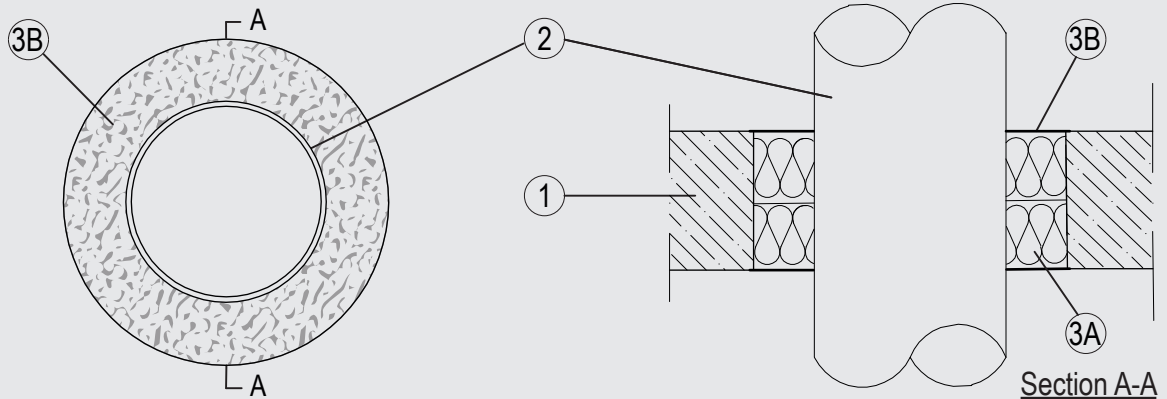

1. Floor and Wall Assembly

Min. 4-1/2 in. (115 mm) thick lightweight or normal weight (100-150 pcf or 1600 - 2400 kg/m³) concrete. Wall may also be constructed of any UL Classified Concrete Blocks*. Opening shall be circular or rectangular with max diameter or dimensions with max. diameter or dimensions 16-3/4 in. (424 mm).

See Concrete Blocks (CAZT) in the Fire Resistance Directory for names of manufacturers.

2. Pipes

Single pipe to be installed within the opening. The annular space between the pipe and the periphery of the opening to be a nom 2 in (50 mm). Pipe to be rigidly supported on both sides of the wall or floor assembly. The following pipes may be used:

- A. Nominal 12-3/4 in. (323.9 mm) diameter (or smaller) Schedule 10 (or heavier) steel pipe.

3. Firestop System

The Through-Penetration Firestop System shall consist of the following:

- A. Packing material — 2 layers of nom. 2-3/8 in. (60 mm) thick mineral wool board min. 9.3 pcf (150 kg/m³) firmly packed into a steel sleeve in the opening of the wall or floor as a permanent form.
 - B. Fill, Void or Cavity Material* — Min. 1/16 in. (2 mm) dry film thickness to be applied inside the aperture before installation and over the full surface of the mineral wool boards, and overlapping onto the wall or floor by min. 3/4 in. (20 mm).
- SVT BRANDSCHUTZ VERTRIEBSGESELLSCHAFT MBH INTERNATIONAL — PYRO-SAFE FLAMMOTECT A

*Indicates such products shall bear the UL or cUL Certification Mark for jurisdictions employing the UL or cUL Certification (such as Canada), respectively.

Please contact us for further information:

✉ Information: global@svt.de Order: order@svt.de

☎ +49 4105-40 90-0